

S07-P

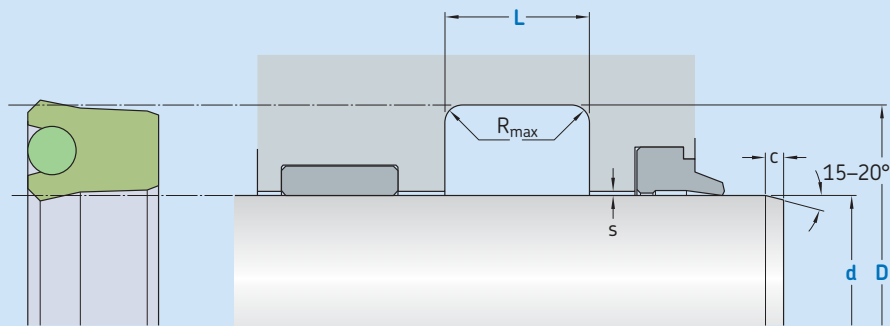

Ordering dimensions in **blue**

Surface roughness	R_{tmax}	R_a
Sliding surface	$\leq 2,5 \mu m$	$0,05-0,3 \mu m$
Bottom of groove	$\leq 6,3 \mu m$	$\leq 1,6 \mu m$
Groove face	$\leq 15 \mu m$	$\leq 3 \mu m$

Bearing area: 50–95% and a cutting depth of $0,5 R_z$ based on $C_{ref} = 0\%$

Standard dimensions						Maximal radial extrusion gap			
d	f8	D	L	R_{max}	c	s^*			
over	incl.	H10	+ 0,2			20 bar	100 bar	200 bar	400 bar
mm						mm			
5	25	d + 8	6,3	0,4	3,5	0,33	0,17	0,11	0,05
25	50	d + 10	8,0	0,4	4,0	0,37	0,22	0,16	0,10
50	150	d + 15	10,0	0,4	5,0	0,46	0,31	0,25	0,19
150	300	d + 20	14,0	0,4	6,0	0,54	0,39	0,32	0,26
300	500	d + 25	17,0	0,4	8,5	0,61	0,46	0,39	0,33
500	600	d + 30	25,0	0,4	10,0	0,67	0,52	0,45	0,39
600	1000	d + 40	32,0	0,4	13,0	0,67	0,52	0,45	0,40
1000	1600	d + 50	40,0	0,4	15,0	0,80	0,60	0,50	0,40

* Extrusion gap values shown above are valid for a temperature of 70 °C, higher temperatures require lower values.

Ordering example

Profile
d x D x L [mm]
Sealing material / Energizer

Rod seal S07-P
100 x 115 x 10
ECOPUR / NBR70

Operating parameters

Material Seal	Energizer	Temperature		Speed ¹⁾	Pressure ²⁾
		from	to	max	max
		°C		m/s	bar (MPa)
■ ECOPUR					
■ ECOPUR LD		-30		0,5	
■ G-ECOPUR	NBR70		+100		400 (40)
■ H-ECOPUR		-20			
■ S-ECOPUR				0,7	
■ T-ECOPUR	MVQ70	-50	+110	0,5	

IMPORTANT NOTE: The stated operating conditions represent general indications. It is recommended not to use all maximum values simultaneously.

¹⁾ Surface speed limit values are valid only in the presence of a lubrication film.

²⁾ Pressure ratings depend on the size of the extrusion gap.