

K08-D

X-Slide

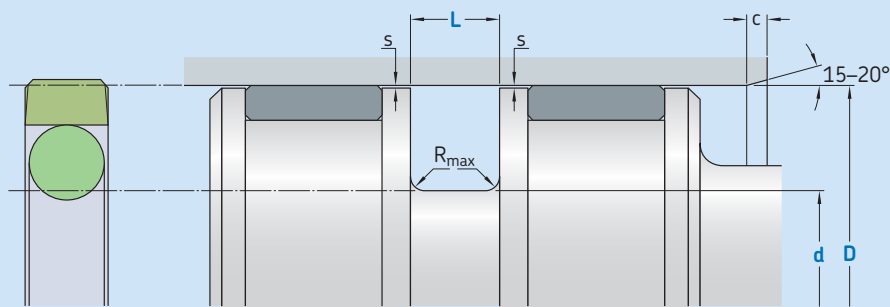

Ordering dimensions in **blue**

Surface roughness	R_{tmax}	R_a
Sliding surface	$\leq 2,5 \mu m$	$0,05-0,2 \mu m$
Bottom of groove	$\leq 6,3 \mu m$	$\leq 1,6 \mu m$
Groove face	$\leq 15 \mu m$	$\leq 3 \mu m$

Bearing area: 50–95% and a cutting depth of $0,5 R_z$, based on $C_{ref} = 0\%$

Standard dimensions							Maximal radial extrusion gap			
D	d	L	R	c	OD	s^*				
H9	h10	$+0,2$				100 bar	200 bar	400 bar	600 bar	
over incl.						mm				
10	15	D-4,9	2,2	0,4	2,5	1,78	0,30	0,20	0,15	0,05
15	40	D-7,5	3,2	0,6	3,5	2,62	0,40	0,30	0,20	0,10
40	80	D-11	4,2	1,0	4,5	3,53	0,50	0,40	0,30	0,20
80	133	D-15,5	6,3	1,3	5,0	5,33	0,50	0,40	0,30	0,20
133	330	D-21	8,1	1,8	6,0	7,00	0,70	0,50	0,40	0,20
330	670	D-24,5	8,1	1,8	8,0	7,00	0,70	0,50	0,40	0,20
670	1 000	D-28	9,5	2,5	10,0	8,40	0,80	0,70	0,50	0,30
1 000	3 000	D-38	13,8	3,0	12,0	12,00	1,10	0,80	0,70	0,40

* The extrusion gap referred to is valid up to 80 °C and valid for the side opposite to the pressure side; higher temperatures require lower values.

Ordering example

Profile
D x d x L [mm]
Sealing material / Energizer

X-Slide K08-D
100 x 84,5 x 6,3
X-ECOPUR / NBR70

Operating parameters

Material Seal	Energizer	Temperature		Speed ¹⁾	Pressure ²⁾
		from	to	max	max
		°C		m/s	bar (MPa)
■ G-ECOPUR 54D ■ X-ECOPUR ■ X-ECOPUR H ■ X-ECOPUR S	NBR70	-30	+100		600 (60)
	MVQ70	-55	+110	5	
■ SKF Ecowear 1000	NBR70	-30	+90		400 (40)
	MVQ70	-55			

IMPORTANT NOTE: The stated operating conditions represent general indications. It is recommended not to use all maximum values simultaneously.

¹⁾ Surface speed limit values are valid only in the presence of a lubrication film.

²⁾ Pressure ratings depend on the size of the extrusion gap.