

# K01-R

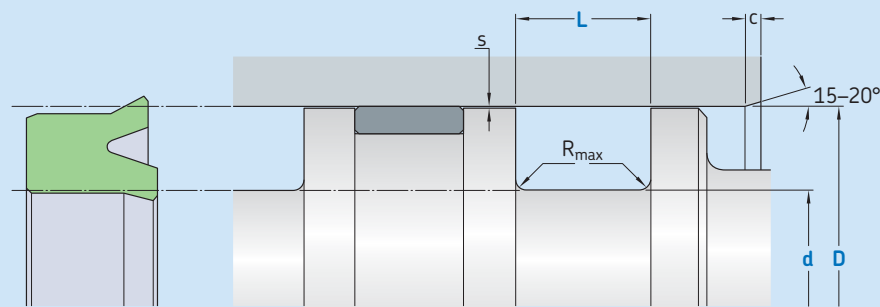

Ordering dimensions in **blue**

Surface roughness	$R_{tmax}$	$R_a$
<b>Sliding surface</b>	$\leq 2,5 \mu m$	$0,05-0,2 \mu m$
<b>Bottom of groove</b>	$\leq 6,3 \mu m$	$\leq 1,6 \mu m$
<b>Groove face</b>	$\leq 15 \mu m$	$\leq 3 \mu m$

Bearing area: 50–95% and a cutting depth of 0,5  $R_z$ , based on  $C_{ref} = 0\%$

### Standard dimensions

D	H9	d	L	$R_{max}$	c	Maximal radial extrusion gap		
over	incl.	h10	+ 0,2			$s^*$		
						20 bar	100 bar	160 bar
mm						mm		
<b>13</b>	<b>25</b>	D - 8	6,0	0,4	3,5	0,23	0,16	0,14
<b>25</b>	<b>50</b>	D - 10	7,0	0,4	4,0	0,26	0,19	0,17
<b>50</b>	<b>75</b>	D - 12	8,0	0,4	4,5	0,29	0,22	0,20
<b>75</b>	<b>150</b>	D - 15	10,0	0,4	5,0	0,32	0,24	0,22
<b>150</b>	<b>300</b>	D - 20	12,0	0,4	6,0	0,35	0,27	0,25
<b>300</b>	<b>500</b>	D - 25	18,0	0,4	8,5	0,39	0,30	0,29
<b>500</b>	<b>750</b>	D - 30	20,0	0,4	10,0	0,40	0,34	0,32
<b>750</b>		D - 40	26,0	0,4	13,0	0,40	0,34	0,32

\* Extrusion gap values shown above are valid for a temperature of 70 °C, higher temperatures require lower values.

### Ordering example

Profile  
D x d x L [mm]  
Sealing material

Piston seal K01-R  
100 x 85 x 10  
SKF Ecorubber-1

## Operating parameters

Material Seal	Temperature		Speed <sup>1)</sup>	Pressure <sup>2)</sup>
	from	to	max	max
–	°C		m/s	bar (MPa)
■ SKF Ecoflas	–10	+200		
■ SKF Ecorubber-H	–25	+150		
■ SKF Ecorubber-1	–30	+100	0,5	160 (16)
■ SKF Ecorubber-2	–20	+200		
■ SKF Ecorubber-3	–50	+150		
■ SKF Ecosil <sup>3)</sup>	–60	+200	–	–

IMPORTANT NOTE: The stated operating conditions represent general indications. It is recommended not to use all maximum values simultaneously.

<sup>1)</sup> Surface speed limit values are valid only in the presence of a lubrication film.

<sup>2)</sup> Pressure ratings depend on the size of the extrusion gap.

<sup>3)</sup> Only recommended for static or quasi-static applications.